



**TCFA-** featuring  
R-22 Refrigerant

**TCFL-** featuring  
Earth-Friendly

R-410A Refrigerant

**R-410A**  
earth friendly refrigerant



Manufactured for  
**Thermal Zone®**  
Philadelphia, PA

## CASED/UNCASED COILS FOR GAS AND OIL FURNACES

**AIRFLOW CAPACITIES**  
**600-1,900 CFM**  
**[283-897 L/s]**

Thermal Zone® Indoor Coils are designed for use with Thermal Zone outdoor units and are available for vertical upflow or downflow, and horizontal left or horizontal right airflow. When matched with Thermal Zone outdoor units, the coils provide a nominal capacity range from 18,000 BTU/HR [5.24 kW] to 60,000 BTU/HR [17.58 kW].

- Constructed of aluminum fins bonded to internally grooved copper tubing.
- Coils are tested at the factory with an extensive refrigerant leak check.
- Coils have sweat refrigerant connections.
- Ideally suited for new installations or add on air conditioning.
- Feature two sets of 3/4" [14.1 mm] N.P.T. Condensate drain connections for ease of connection.
- Coils are A.R.I. certified for system application with variety of Thermal Zone outdoor units.
- Condensate drain pan is constructed of high grade, heat resistant, corrosion free thermal-set material.
- Compatible with Germicidal Light System (UV resistant)
- Bi-Directional airflow eliminates the need to switch any internal components from horizontal left to right.
- Unique drain pan design maximizes application flexibility and condensate removal.
- Universal Duct Flanges are included with all coil models.



# MODEL NUMBER DATA

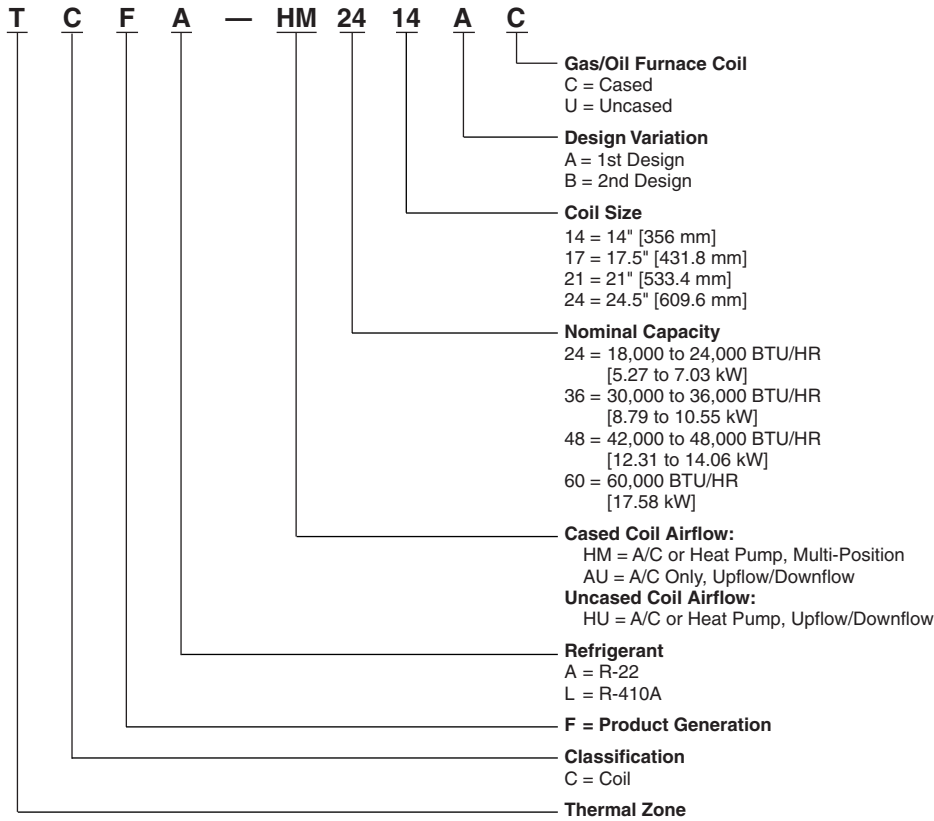

<b>Available Models of TCFA(L) Coils</b>	
TCFA(L)-HM2414AC	TCFA(L)-AU4821BC
TCFA(L)-HM2417AC	TCFA(L)-AU4824BC
TCFA(L)-HM3617AC	TCFA(L)-AU6024BC
TCFA(L)-HM3621AC	TCFA(L)-HU2414AU
TCFA(L)-HM4821AC	TCFA(L)-HU2417AU
TCFA(L)-HM4824AC	TCFA(L)-HU3617AU
TCFA(L)-HM6024AC	TCFA(L)-HU3621AU
TCFA(L)-AU2414BC	TCFA(L)-HU4821AU
TCFA(L)-AU2417BC	TCFA(L)-HU4824AU
TCFA(L)-AU3617BC	TCFA(L)-HU6024AU
TCFA(L)-AU3621BC	

**Table 1: Coil Specifications/Airflow Pressure Drop**

Coil Model TCFA/ TCFL	Approx. Design Air Flow CFM [L/s] Range	Face Area Sq. Ft. [m <sup>2</sup> ]	Fins-in. Rows Deep	Static Pressure Drop Through Wet Cooling Coil [kPa] (Inches W.C.) CFM [L/s]														
				600 [285]	700 [330]	800 [380]	900 [425]	1000 [470]	1100 [519]	1200 [565]	1300 [614]	1400 [660]	1500 [708]	1600 [755]	1700 [802]	1800 [850]	1900 [897]	
<b>HIGH EFFICIENCY COOLING COILS</b>																		
2414	600/1000 [283/472]	4.56 [0.42]	16/2	.17 [.043]	.21 [.053]	.25 [.063]	.31 [.080]	.40 [.100]	.46 [.117]	—	—	—	—	—	—	—	—	
2417	600/1000 [283/472]	4.56 [0.42]	16/2	.15 [.039]	.19 [.049]	.23 [.059]	.30 [.076]	.38 [.096]	.45 [.113]	—	—	—	—	—	—	—	—	
3617	900/1400 [424/661]	5.70 [0.53]	16/2	—	—	.17 [.043]	.21 [.053]	.26 [.064]	.31 [.080]	.36 [.092]	.41 [.103]	—	—	—	—	—	—	
3621	900/1400 [424/661]	5.70 [0.53]	16/2	—	—	.15 [.038]	.18 [.047]	.23 [.058]	.27 [.069]	.31 [.080]	.37 [.094]	—	—	—	—	—	—	
4821	1200/1800 [566/850]	8.55 [0.79]	16/2	—	—	—	—	—	—	.22 [.056]	.25 [.063]	.28 [.071]	.32 [.081]	.36 [.092]	.41 [.103]	—	—	
4824	1200/1800 [566/850]	8.55 [0.79]	16/2	—	—	—	—	—	—	.22 [.056]	.25 [.063]	.28 [.071]	.32 [.081]	.32 [.081]	.41 [.103]	—	—	
6024	1600/1900 [755/897]	9.98 [0.93]	14/3	—	—	—	—	—	—	—	—	—	—	—	.27 [.070]	.30 [.076]	.34 [.084]	.37 [.094]

NOTE: Represents Coil-Only Airflow Ratings

[ ] Designates Metric Conversions

**Table 2: Coil Dimensions and Weights**

Coil Model TCFA/TCFL	Connections		Cased Coil Dimensions (in) [mm]			Weight	
	Sweat (in.) [mm]		A	B	C	Coil Weight (lbs.) [Kg.]	Shipping Weight (lbs.) [Kg.]
	Liquid	Suction					
	I.D.	I.D.					
2414*	3/8 [9.53]	3/4 [19.05]	14 [356]	21 [533]	23 <sup>3</sup> / <sub>16</sub> [584]	46 [21]	50 [23]
2417	3/8 [9.53]	3/4 [19.05]	17 <sup>1</sup> / <sub>2</sub> [445]	14 <sup>1</sup> / <sub>2</sub> [368]	20 [508]	46 [21]	51 [23]
3617	3/8 [9.53]	3/4 [19.05]	17 <sup>1</sup> / <sub>2</sub> [445]	17 <sup>7</sup> / <sub>8</sub> [454]	20 [508]	52 [24]	57 [26]
3621	3/8 [9.53]	3/4 [19.05]	21 [533]	17 <sup>1</sup> / <sub>2</sub> [445]	20 [508]	54 [24]	60 [27]
4821	3/8 [9.53]	7/8 [22.23]	21 [533]	25 <sup>7</sup> / <sub>8</sub> [657]	28 [711]	76 [34]	83 [38]
4824	3/8 [9.53]	7/8 [22.23]	24 <sup>1</sup> / <sub>2</sub> [622]	25 <sup>3</sup> / <sub>8</sub> [645]	32 [812]	89 [40]	99 [45]
6024	3/8 [9.53]	7/8 [22.23]	24 <sup>1</sup> / <sub>2</sub> [622]	30 <sup>1</sup> / <sub>4</sub> [768]	32 [812]	108 [49]	118 [55]

\*The 14 inch, 2 ton TCFA/TCFL coil (2414) is part of the "N-Coil" design series, even though the coil shape resembles an "A" coil design.

[ ] Designates Metric Conversions

**FIGURE 1: DIMENSIONS**

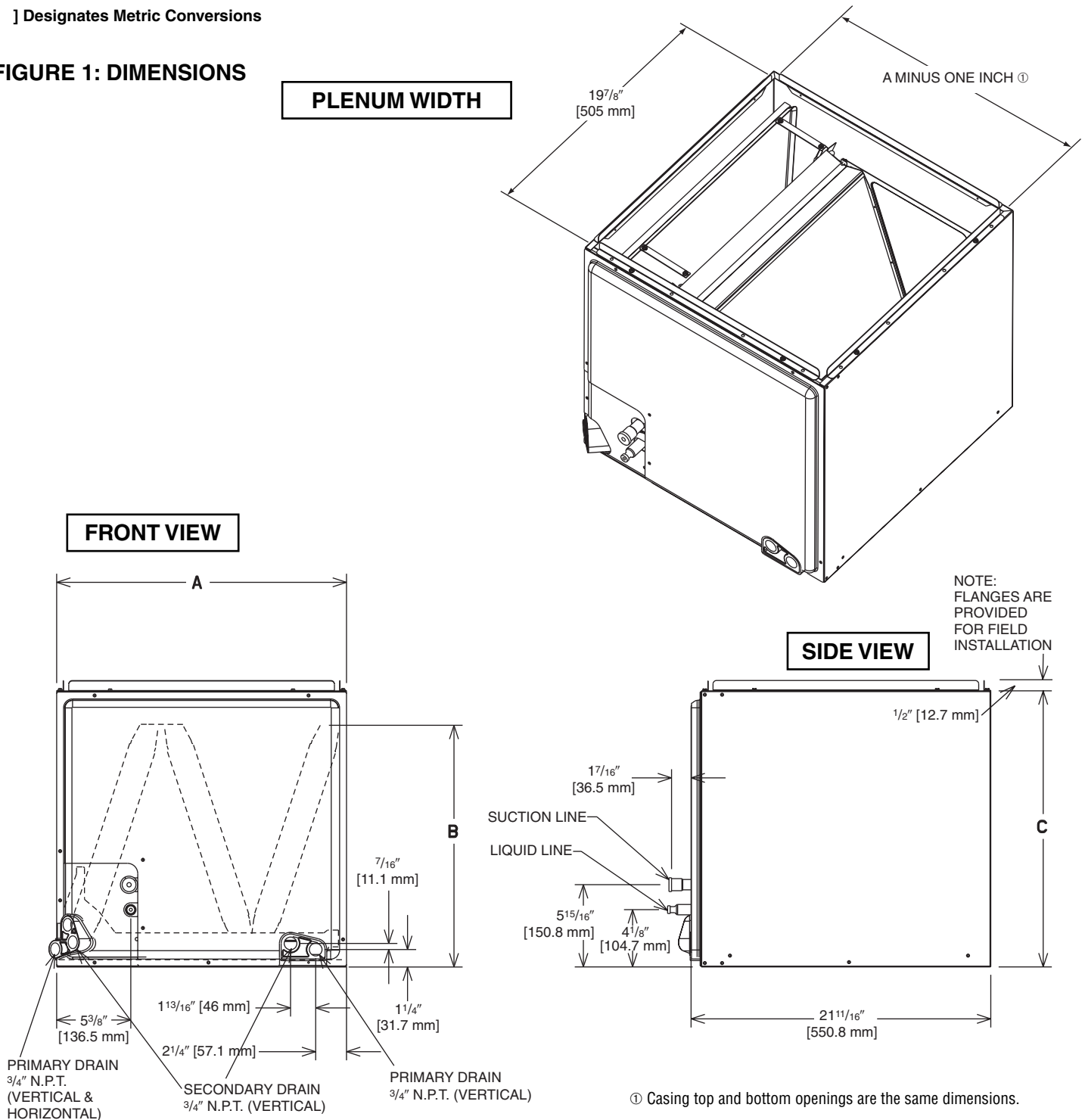

[ ] Designates Metric Conversions

## Table 3: Coil Application

Coils can be matched to heating products as listed in table below.

Coil Model TCFA/TCFL	Furnace Width (In.) (mm)	
	Oil	Gas
2414 2417 3617	—	14 [356]
2417 3617	21 [533]	17½ [444] 14 [356]
3621 4821	21 [533]	21 [533] 17½ [444]
4824 6024	24½ [622]	24½ [622] 21 [533]

\*Note: Due to the proximity of the drain pan to the high temperature oil furnace drain, horizontal left application is not permitted on all oil furnaces.

## Accessories

### • PLENUM ADAPTER ACCESSORY RXBA-AE

This plenum adapter accessory is for use with the 24½" wide cased indoor cooling and heat pump coils. This allows a 24½" wide cased coil to be installed on a 28" wide oil furnace. This is a field-installed accessory only.

### • RXBA-AC (Upflow/Horizontal)

These plenum adapter accessories are for use when a cooling coil is matched with a gas furnace of one smaller size.

### • HORIZONTAL ADAPTER KIT RXHH (See Figure 2)

This horizontal adapter kit is used to convert a upflow or downflow coil for a horizontal application. See Table 4 to order the proper horizontal adapter kit.

\*Note: The horizontal adapter kit cannot be used for TCFA/TCFL-AU\*\*\*\*BC applications. It can only be used on TCFA/TCFL-AU\*\*\*\*AC applications and for TCFA/TCFL-HU\*\*\*\*AC applications.

Table 4: Horizontal Adapter Kit Model No.

Coil Model	Horizontal Adapter Kit Model No.
2414	RXHH-A01
2417	RXHH-A02
3617/3621	RXHH-A03
4821/4824	RXHH-A04
6024	RXHH-A05

FIGURE 2: HORIZONTAL ADAPTER KIT ILLUSTRATION

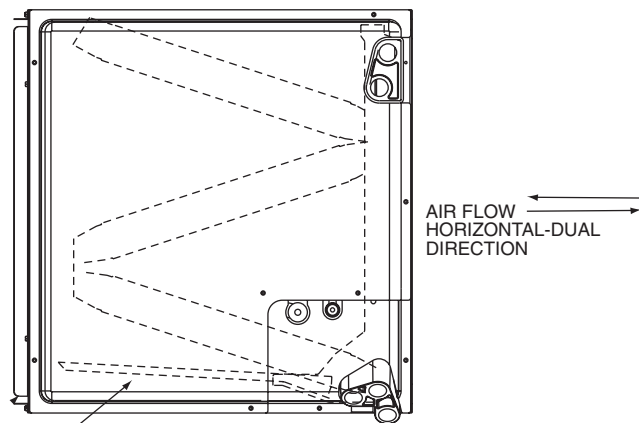

HORIZONTAL ADAPTER KIT (RXHH-)

### • INDOOR COIL CASING- RXBC (See Table 5)

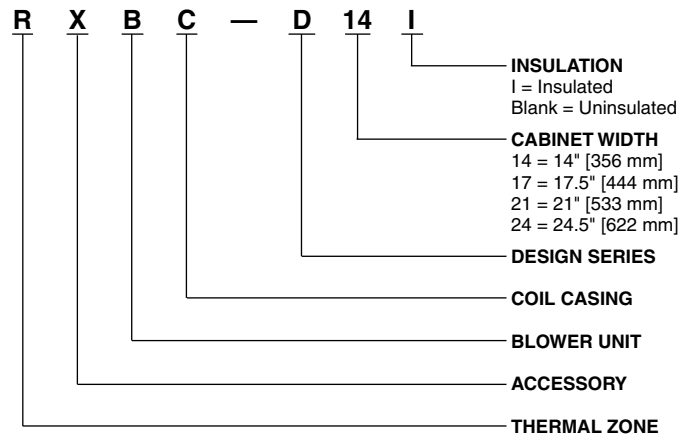

Table 5: Unit Dimensions and Weights- RXBC Indoor Coil Casings

Model Number	Width (in.) [mm]	Height (in.) [mm]	Depth (in.) [mm]	Unit Weight		Supply Air/Return Air Openings	
				Weight (lbs.) [Kg.]	Ship. Wt. (lbs.) [Kg.]	Width (in.) [mm]	Depth (in.) [mm]
RXBC-D14AI	14 [356]	23 <sup>3</sup> / <sub>16</sub> [589]	21 <sup>5</sup> / <sub>8</sub> [549]	19 [9]	23 [10]	13 [330]	19 <sup>31</sup> / <sub>32</sub> [508]
RXBC-D17AI	17½ [445]	20 [508]		18 [8]	23 [10]	16½ [419]	
RXBC-D21AI	21 [533]	20 [508]		20 [9]	26 [12]	20 [508]	
RXBC-D21BI	21 [533]	28 [711]		27 [12]	36 [17]	20 [508]	
RXBC-D24AI	24½ [622]	32½ [826]		34 [16]	44 [20]	23½ [597]	

[ ] Designates Metric Conversions

## Accessories (cont.)

### • UNCASSED COIL ADAPTER KIT RXBA- (See Figure 3 & 4)

This uncased coil adapter kit is used to adapt the coil to a furnace or ductwork. See Table 6 to order the proper adapter kit. Each kit contains a quantity of 20 adapters.

**Table 6: Uncased Coil Adapter Kit**

Uncased Coil Adapter Model Number RXBA	A Width (in.) [mm]	Uncased Coil Model TCFA/L
B14x20	13 <sup>1</sup> / <sub>8</sub> [333]	-HUxx14
B17x20	16 <sup>5</sup> / <sub>8</sub> [422]	-HUxx17
B21x20	20 <sup>1</sup> / <sub>8</sub> [511]	-HUxx21
B24x20	23 <sup>5</sup> / <sub>8</sub> [599]	-HUxx24

**FIGURE 3: UNCASSED COIL ADAPTER KIT ILLUSTRATION**

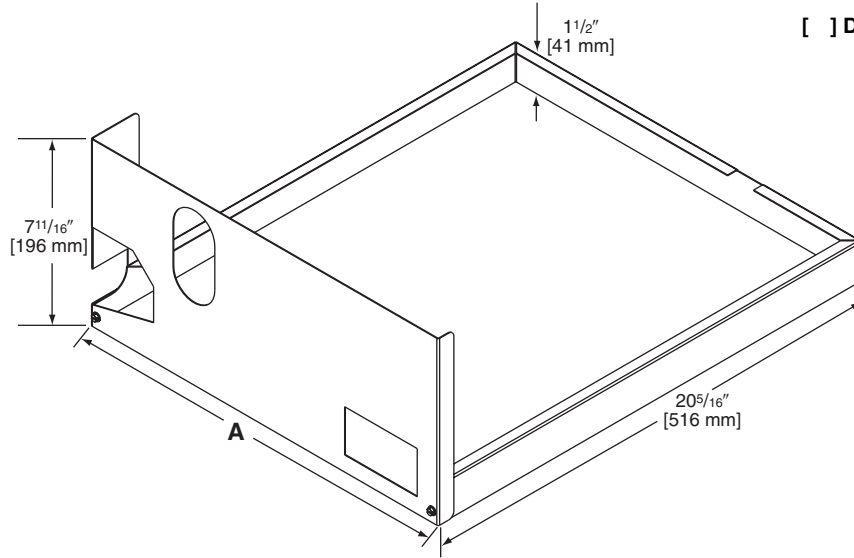

[ ] Designates Metric Conversions

**FIGURE 4: UNCASSED COIL ADAPTER KIT ASSEMBLED**

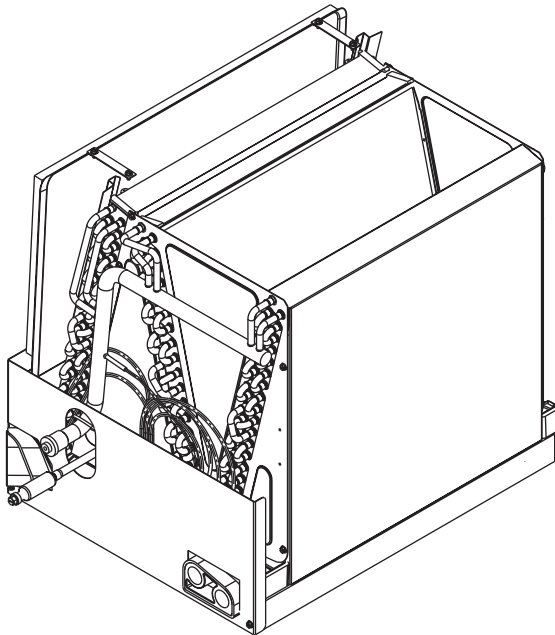

Note: Sliding the coil into the coil rail before attaching coil rack front.

# NOTES

## NOTES

---

**Before proceeding with installation, refer to installation instructions packaged with each model, as well as complying with all Federal, State, Provincial, and Local codes, regulations, and practices.**

---

*"In keeping with its policy of continuous progress and product improvement, the right is reserved to make changes without notice."*